

GALINTEL® STEEL LINTELS



SELECTION GUIDE & LOAD TABLES



GALINTEL PTY LTD

GALINTEL PTY LTD

A division of the Graham Group
An Australian owned Company
with more than 50 years' experience

The Graham Group is now part of the Nepean Group, one of Australia's leading privately owned engineering and industrial manufacturing conglomerates.

Galintel is Australia's leading designer and manufacturer of high quality steel lintels for the building industry. The specialised range of lintels includes flats, angles, T-bars and Rendabar®, all designed for optimum support of brickwork above clear openings

The innovative design of Galintel® products enables weight savings of up to 40% while maintaining strength, structural rigidity and load bearing capacity.

Galintel® products are hot-dip galvanised to Australian Standards to ensure that all surfaces (legs, edges and ends) are fully protected.

Products undergo CSIRO Building Products & Systems Appraisal and comply with the requirements of the Building Code of Australia. Engineering certification of structural adequacy is verified by independent testing at the University of NSW and Sydney University.

Galintels® are approved by housing authorities and local government bodies in all states.

CONTENTS

Company Profile	2
General Information	3
Solid Base Angles & Flats	4
Traditional Angles	6
Rendabar®	7
Multi-Rib T-Bar	9
Traditional T-Bar	10
Cavi-T-Bar™	11
T-Bar Section Properties	13
Frequently Asked Questions	14
Stock Length Guide	15



GALINTEL® HOT-DIP GALVANISED STEEL LINTELS

BEST LINTEL BAR NONE

R3 DURABILITY RATING 25-YEAR WARRANTY*

Use the simple guides in this brochure and select the right Galintel® every time, for:

- Peace of mind
- Superior performance
- Long life and durability

Genuine Galintel® hot-dip galvanised steel lintels are 40% lighter than solid lintels (and 40% easier to carry) with a high strength to weight ratio.

The ribbed Galintel® profile creates a superior bond with the mortar. The brickwork, mortar and lintel work together to form a composite beam with exceptional strength and load-carrying capacity.

You won't have to worry about corroded lintels and cracked brickwork, thanks to the generous galvanising layer – including the ends of the product where corrosion often begins.

All Galintel® bars comply with the following standards:

- Hot-dip galvanised to AS/NZS4680:2006
- Up to R3 durability ratings in accordance with AS/NZS2699.3:2001
- Loads in accordance with AS/NZS1170.1:2002

Compliance with codes and standards is guaranteed – Galintels® have CSIRO approval, backed by research conducted by the University of NSW and Sydney University..

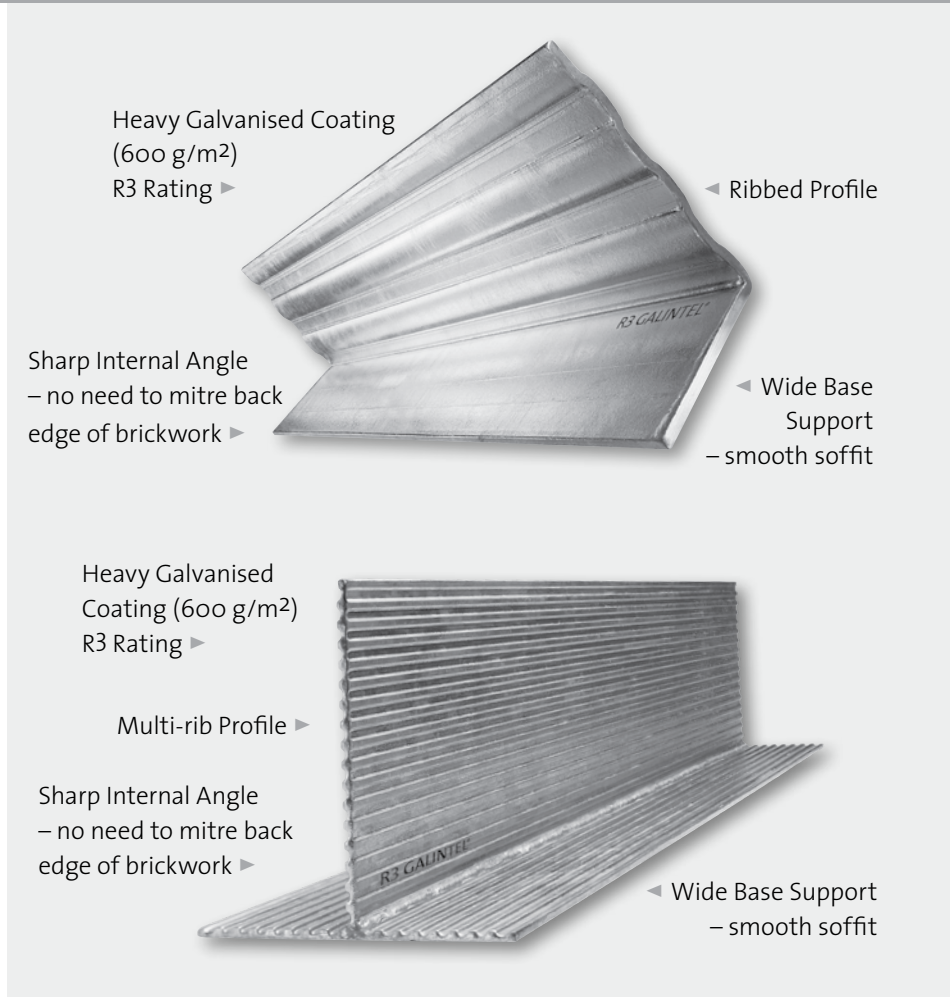

Durability & corrosion resistance (R3 rating)

All Galintel® products are hot-dip galvanised with a heavy zinc coating of 600 g/m² which complies with an R3 durability rating. Durability is a function of the thickness of the zinc coating (black steel is classified as R0 and stainless steel as R5). Galintels® can achieve an R4 durability rating when coated with a two-part epoxy coating (contact Galintel for specification sheet).

Product Warranty

All Galintel® products are guaranteed against defects in materials and workmanship.

Galintel Pty Ltd further warrants that its products will suffer no loss of function nor will they adversely affect the masonry within 25 years from the date of installation. For full warranty conditions and registration details visit our website www.galintel.com.au.

Don't settle for substitutes. Look for the Galintel® brand.

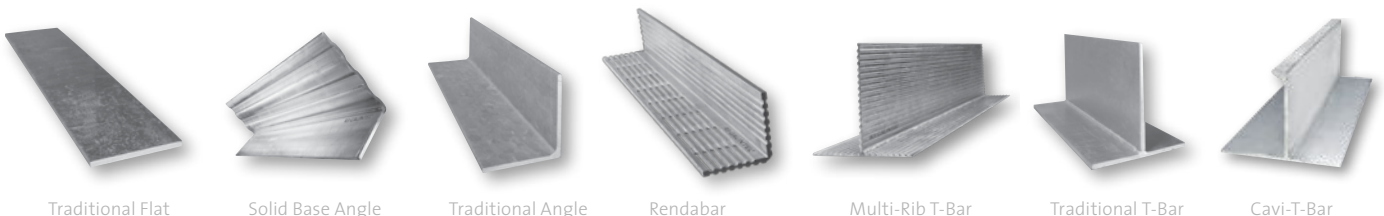

GALINTEL® SOLID BASE ANGLES & FLATS

QUICK SELECTION GUIDE

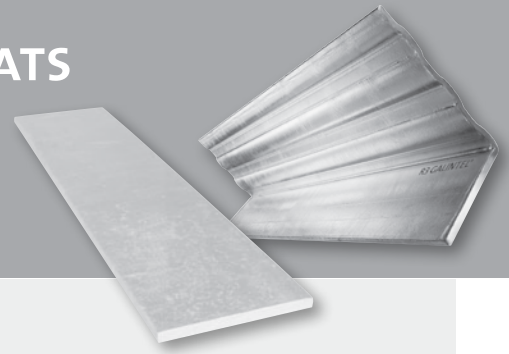

How to use the quick selection guide

1. Determine the Loading Category by referring to the diagrams below.
2. Determine the span of the opening, including end bearings, and use the Clear Span Length table to find the appropriate Galintel® profile.
3. Determine the load to be applied to the Galintel® and refer to the Safe Load tables on page 5 to find the correct profile size and stock length.

Example:

Loading Category B (cavity wall construction), 1800mm span with UDL of 1400 kg/m. From the safe load tables on page 5, this requires a Galintel® Solid Base Angle with 150mm x 100mm profile and stock length of 2100mm.

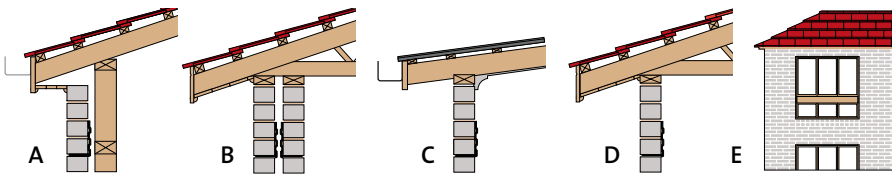

These diagrams represent general domestic and light commercial construction only, using conventional framing materials and standard building practices.

All load-bearing walls must have at least three courses of bricks over the opening. The wall above the opening should not be subjected to major loads other than those from normal roof, ceiling and floors. Avoid point loads above the opening, such as hot water tanks and roof storage areas.

Category E loadings that do not comply with the above conditions should be referred to a structural engineer.

Construction Category

Category A

Non-load bearing brick veneer with separate structural timber frame.

Category B

Cavity wall equally supported on both skins. Supported roof span < 8m.

Category C

Lightweight sheet roof and ceiling supported on single skin. Supported roof span < 8m.

Category D



Lightweight timber truss, tiled roof and sheet ceiling supported on single skin. Supported roof span < 8m.

Category E

Load-bearing internal brickwork under upper storeys. Supported floor span < 8m.

Now find the right Galintel profile for your clear span

Follow the colour code from the loading categories above. Add end bearing of 100-150mm to both ends of span.

PROFILE SIZE & LOADING CATEGORY		CLEAR SPAN LENGTH											
		600	700	800	900	1200	1500	1800	2100	2400	2700	3000	3600
 FLAT BAR 85 x 7 5 kg/m	Category A												
	Category B												
	Category C												
	Category D												
	Category E												
 ANGLE BAR 100 x 100 9kg/m	Category A												
	Category B												
	Category C												
	Category D												
	Category E												
 ANGLE BAR 150 x 100 12kg/m	Category A												
	Category B												
	Category C												
	Category D												
	Category E												

Disclaimer: Information contained in this brochure does not constitute an offer and is supplied in good faith to aid the user in the correct selection of our products. Every care has been taken to ensure that the information is correct; however, we cannot guarantee its accuracy or completeness and we assume no responsibility for errors or omissions or for any consequences of reliance on this publication.

Galintel Pty Ltd is committed to continual improvements in our products and we reserve the right to change specifications, details and designs without notice. All dimensions and masses in this brochure are nominal.

Refer to load tables on page 5 for correct profile size and length

GALINTEL® SOLID BASE ANGLES & FLATS

SAFE LOAD TABLES

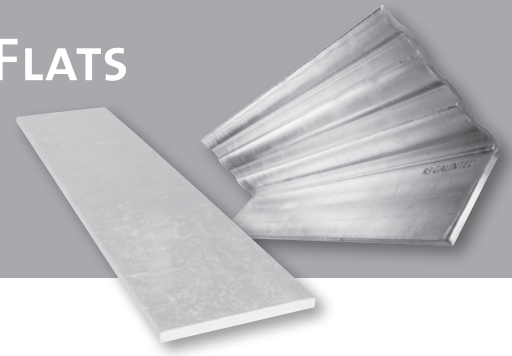



Angles & Flats – safe load tables

Unless otherwise indicated, load values in the tables are limited by stress. For example, for a span of 2100mm, a 150 x 100 x 2400 Galintel® may have a load of 949 kg/m applied safely, with a maximum long term deflection of 1/600 span or 3.5mm (2100/600 = 3.5).

All tables are intended as a guide only. Qualified expert advice should be sought in deciding the suitability of any structural product for a construction application.

UDL = Uniform distributed load

		FLAT BAR					SOLID BASE ANGLE			
FLAT BAR 85 x 7 5 kg/m 	Span (mm)	600	700	800	900	1000				
	Bar Length (mm)	800	900	1000	1100	1200				
	Total Load (kg)	43.7	32.1	24.5	19.4	15.7				
	UDL (kg/m)	72.8	45.9	30.6	21.6	15.7				
	Total Load (kg)	72.8	53.4	40.9	32.3	26.2				
	UDL (kg/m)	121.3	76.3	51.1	35.9	26.2				
ANGLE BAR 100 x 100 x 6 9kg/m 	Span (mm)	1000	1200	1500	1800	2100	2400	2700	3000	
	Bar Length (mm)	1200	1500	1800	2100	2400	2700	3000*	3300*	
	Load (kg)	2083	1736	1265	878	645	486	384	311	
	UDL (kg/m)	2083	1447	843	488	307	203	142	104	
	Load (kg)	2083	1736	1389	1157	992	811	641	519	
	UDL (kg/m)	2083	1447	926	643	472	338	237	173	
ANGLE BAR 150 x 100 x 6 12kg/m 	Span (mm)	1500	1800	2100	2400	2700	3000	3600		
	Bar Length (mm)	1800	2100	2400	2700	3000	3300	4000		
	Load (kg)	3024	2520	1993	1526	1206	976	676		
	UDL (kg/m)	2016	1400	949	636	447	325	188		
	Load (kg)	3024	2520	2100	1890	1680	1512	1312		
	UDL (kg/m)	2016	1400	1000	788	622	504	364		

□ Loads not limited by deflection ■ Loads limited by short term deflection of 1/600 span ▨ Loads limited by short term deflection of 1/360 span

Control Joints

Where control joints are used as a required structural element, loading of the lintel should be reduced by one third.

Propping

For best results all lintels must be propped before bricklaying. Props must be no further than 1.2m apart and must remain in place until the mortar has fully cured.

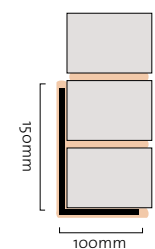

Brick composite beam
 Minimum 3 courses of bricks.
 Note: Mortar should be present at all contact surfaces between bricks and lintel

Composite Action

Galintel® products rely on composite action. Therefore, to achieve ultimate performance, mortar must be present at all contact surfaces between bricks and lintel.

GALINTEL® TRADITIONAL ANGLES

QUICK SELECTION GUIDE & SAFE LOAD TABLES

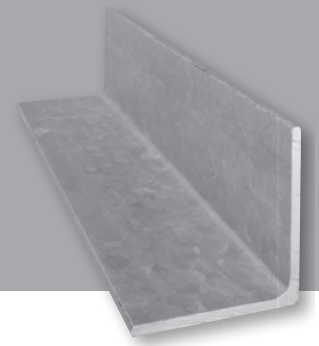

Quick selection guide

Use the Quick Selection Table to find an appropriate profile and length for the required span and Construction Category (see page 4). Include end bearing lengths of 100mm on both ends of bar (for openings up to 1000mm) or 150mm (for openings greater than 1000mm). Use the Safe Load Tables to determine which product will safely carry the load.

Quick Selection Table

		CLEAR SPAN LENGTH (mm)							
		900	1200	1500	1800	2100	2400	2700	3000
TRADITIONAL ANGLE 100 x 75 x 10 13 kg/m	Category A								
	Category B								
	Category C								
	Category D								
	Category E								
TRADITIONAL ANGLE 150 x 90 x 10 18 kg/m	Category A								
	Category B								
	Category C								
	Category D								
	Category E								
TRADITIONAL ANGLE 150 x 100 x 10 19 kg/m	Category A								
	Category B								
	Category C								
	Category D								
	Category E								

Galintel® Traditional Angles – safe load tables

Note a minimum of three courses of bricks must be laid above the lintel.

Loads limited by deflection of 1/600 span

TRADITIONAL ANGLE 100 x 75 x 10 13 kg/m	Span (mm)	900	1200	1500	1800	2100	2400	2700	
	Bar Length (mm)	1200	1500	1800	2100	2400	2700	3000	
	Total Load (kg)	1345	1005	805	670	575	500	415	
	UDL (kg/m)	1494	840	538	373	274	210	154	
	Point Load (kg)	670	500	400	335	285	250	220	
TRADITIONAL ANGLE 150 x 90 x 10 18 kg/m	Span (mm)	1500	1800	2100	2400	2700	3000	3300	3600
	Bar Length (mm)	1800	2100	2400	2700	3000	3300	3600	4000
	Total Load (kg)	3995	3090	2270	1735	1370	1110	915	770
	UDL (kg/m)	2664	1717	1081	724	508	370	278	214
	Point Load (kg)	1995	1665	1275	975	770	625	515	430
TRADITIONAL ANGLE 150 x 100 x 10 19 kg/m	Span (mm)	1800	2100	2400	2700	3000	3300	3600	
	Bar Length (mm)	2100	2400	2700	3000	3300	3600	4000	
	Total Load (kg)	3205	2355	1800	1425	1150	950	800	
	UDL (kg/m)	1781	1121	751	527	384	289	222	
	Point Load (kg)	1690	1325	1010	800	645	535	450	

Notes on safe load tables for Traditional Angles

Loads given are total (allowable) loads including lintel and brickwork.

These load tables assume that bricks

and props fully restrain the lintel against twisting and local buckling of compression leg. Non-composite action was used in the calculations.

UDL for each Construction Category was based on 8m of supported span

of floor or roof (of which 4m is taken by the section being considered). Six courses of bricks were considered for each category. UDLs for each Loading Category in kg/m were: A – 124, B – 374, C – 391, D – 605, E – 2202, F – 1020.

GALINTEL RENDABAR®

SAFE LOAD TABLES (100 x 100)



Galintel Rendabar® is a total load bearing bar, specifically designed to facilitate cement rendering.

The bond between mortar, brickwork and lintel forms a composite beam of superior strength and structural integrity.

The platform leg provides a wide base of support for brickwork and a generous keying area for cement rendering.

Light weight, rigidity

Galintel Rendabars® are considerably lighter than other forms of lintels, contributing to ease of handling and faster construction and less potential damage to green masonry.

Mortar bonding with the multi-ribbed section locks the Rendabar® firmly to the masonry, providing superior lateral bracing and rigidity.

RENDABAR 100 x 100 x 8 9 kg/m		POINT LOAD (kg) 600mm TRUSS SPACING					
		Span (mm)	900	1200	1500	1800	2100
	Rendabar (mm)	1200	1500	1800	2100	2400	2700
	Brick courses 3	895	430	510	335	350	235
	4	1560	710	805	490	470	290
	5	1875	845	940	570	530	315
	6	2205	990	1100	655	610	360

RENDABAR 100 x 100 x 8 9 kg/m		POINT LOAD (kg) 900mm TRUSS SPACING					
		Span (mm)	900	1200	1500	1800	2100
	Rendabar (mm)	1200	1500	1800	2100	2400	2700
	Brick courses 3	595	570	545	260	290	210
	4	1040	950	855	380	395	385
	5	1250	1125	1005	440	445	425
	6	1470	1320	1170	510	510	480

RENDABAR 100 x 100 x 8 9 kg/m		DISTRIBUTED LOAD (kg/m)					
		Span (mm)	900	1200	1500	1800	2100
	Rendabar (mm)	1200	1500	1800	2100	2400	2700
	Brick courses 3	1120	805	615	490	400	330
	4	1950	1335	965	720	540	410
	5	2340	1585	1130	825	610	450
	6	2760	1860	1320	955	700	505

Fire-rated Rendabar® – safe load table (100 x 100)

Use this table when a fire resistance rating is required (at least 15mm of cement render must be applied to underside of lintel).

RENDABAR 100 x 100 x 8 9 kg/m		MAXIMUM LOAD (kg/m)						
		Span (mm)	600	900	1200	1500	1800	2100
	Rendabar (mm)	900	1200	1500	1800	2100	2400	
	Fire Resistance Level	60 min	6810	3025	1705	1090	755	555
	Fire Resistance Level	90 min	5060	2250	1265	810	560	415
	Fire Resistance Level	120 min	4445	1975	1110	710	495	365

C.S.I.R.O. Opinion FOC-1242

GALINTEL RENDABAR®

SAFE LOAD TABLES (150 x 100)



Control joints

Where control joints are used as a required structural element, loading of the lintel must be reduced by one-third.

Propping

Rendabar® spans must be propped or tommed at equal intervals (not more than 1.2m apart) when brickwork is laid up rapidly over and above two courses.

Code compliance

Galintel Rendabars® have been extensively tested by Unisearch Limited, the research and development company of the University of New South Wales, for strength, structural adequacy, and compliance with relevant Australian Building Codes. ABSAC approved (Technical opinion No.205).

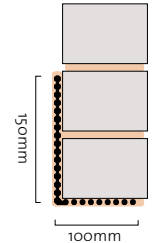

Brick composite beam
Minimum 3 courses of bricks.
Note: Mortar must be present at all contact surfaces between bricks and Rendabar

Composite Action

Galintel® products rely on composite action. Therefore, to achieve ultimate performance, mortar must be present at all contact surfaces between bricks and lintel.

RENDABAR 150 x 100 x 8 11 kg/m		POINT LOAD (kg) 600mm TRUSS SPACING					
		Span (mm)	1800	2100	2400	2700	3000
	Rendabar (mm)	2100	2400	2700	3000	3300	3600
	Brick courses 3	390	385	250	N/A	N/A	N/A
	4	600	615	410	425	305	300
	5	785	830	575	620	470	485
	6	910	975	685	760	585	615

RENDABAR 150 x 100 x 8 11 kg/m		POINT LOAD (kg) 900mm TRUSS SPACING					
		Span (mm)	1800	2100	2400	2700	3000
	Rendabar (mm)	2100	2400	2700	3000	3300	3600
	Brick courses 3	305	325	330	N/A	N/A	N/A
	4	470	510	545	325	315	305
	5	615	690	765	475	485	490
	6	705	810	915	575	600	625

RENDABAR 150 x 100 x 8 11 kg/m		DISTRIBUTED LOAD (kg/m)					
		Span (mm)	1800	2100	2400	2700	3000
	Rendabar (mm)	2100	2400	2700	3000	3300	3600
	Brick courses 3	570	445	350	N/A	N/A	N/A
	4	875	705	575	475	390	325
	5	1150	950	805	690	600	525
	6	1325	1120	965	850	745	665

N/A indicates not applicable

Fire-rated Rendabar® – safe load table (150 x 100)

Use this table when a fire resistance rating is required (at least 15mm of cement render must be applied to underside of lintel).

RENDABAR 150 x 100 x 8 11 kg/m		MAXIMUM LOAD (kg/m)							
		Span (mm)	1500	1800	2100	2400	2700	3000	3300
	Rendabar (mm)	1800	2100	2400	2700	3000	3300	3600	
	Fire Resistance Level	60 min	1220	845	620	475	375	305	250
	Fire Resistance Level	90 min	905	630	460	355	280	225	N/A
	Fire Resistance Level	120 min	795	550	405	310	245	N/A	N/A

C.S.I.R.O. Opinion FOC-1242

GALINTEL® MULTI-RIB T-BAR

SAFE LOAD TABLES

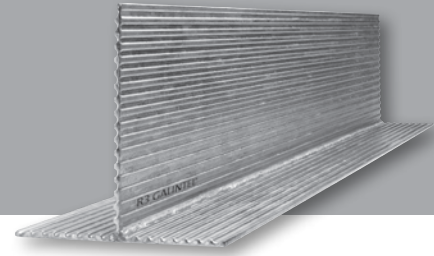

Galintel® Multi-Rib T-Bars are cost-effective lintels that provide structural rigidity, high strength-to-weight ratio and resistance to corrosion.

The multi-ribbed profile forms a superior bond with the mortar. This bond between mortar, brickwork and lintel creates a composite beam of superior strength and structural integrity.

The Galintel® Multi-Rib T-Bar is a total load bearing lintel designed to support 230mm brickwork over a clear opening.

Installation

Place Galintel® Multi-Rib T-Bar in position on brick piers, with minimum end bearing of 150mm.

Prop before bricklaying. Props must be no further than 1.2 metres apart and must remain in place until mortar has fully cured.

Apply mortar (minimum 1:4) to all brick faces in contact with the T-Bar.

The same number of courses must be laid internally and externally to prevent twisting of the T-Bar.

Composite Action

Galintel® products rely on composite action. Therefore, to achieve ultimate performance, mortar must be present at all contact surfaces between bricks and lintel.

Control Joints

Where control joints are used as a required structural element, loading of the lintel should be reduced by one third.

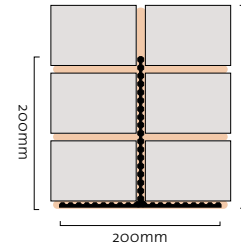

Brick composite beam
Minimum 3 courses of bricks.
Note: Mortar must be present at all contact surfaces between bricks and T-Bar

Notes on safe load tables for Multi-Rib T-Bar

The tables show the number of brick courses needed to safely carry the total load across the clear span opening.

Determine the load to be carried by the T-Bar (e.g. roof, framing, etc., plus live load allowance) but excluding lintel and bricks.

Total load is expressed as kg for point loads or kg/m for distributed loads. Where more than 4 equal point loads are applied, use the Distributed Load tables.

The spans shown are clear openings. The length of T-Bar ordered must include a minimum end bearing allowance of 150mm at both ends.

Galintel® Multi-Rib T-Bar safe load tables

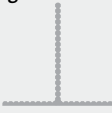
MULTI-RIB T-BAR 200 x 7 (vertical leg) 200 x 7 (platform leg) 18 kg/m	Span (mm)	POINT LOAD (kg)				DISTRIBUTED LOAD (kg/m)		
		2400	2700	3000		2400	2700	3000
	T-Bar Length	2700	3000	3300		2700	3000	3300
	Brick courses 3	2735	2700	2395	3	1135	1010	910
	4	3310	3310	2980	4	1380	1225	1100
	5	4520	4215	3745	5	1880	1670	1505
	6	5730	5280	4690	6	2385	2120	1910

MULTI-RIB T-BAR 200 x 9 (vertical leg) 200 x 9 (platform leg) 23 kg/m	Span (mm)	POINT LOAD (kg)				DISTRIBUTED LOAD (kg/m)		
		4800	5100	5400		4800	5100	5400
	T-Bar Length	5100	5400	5700		5100	5400	5700
	Brick courses 3	830	730	650	3	270	230	190
	4	1110	980	870	4	370	300	250
	5	1770	1570	1400	5	590	490	410
	6	2650	2350	2090	6	880	730	620

The Galintel® T-Bar is a welded galvanised T-section comprising two multi-ribbed steel plates, 200mm wide with a nominal thickness of 7 or 9mm (depending on the length). The steel conforms to AS3678-250 with a minimum ultimate tensile strength of 410 MPa and yield strength of 280 MPa. Welding is conducted to the requirements of AS4100-1990 and galvanising conforms to AS/NZS 4680:2006.

GALINTEL® TRADITIONAL T-BARS

SAFE LOAD TABLES

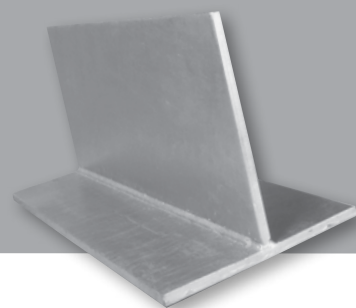

Traditional T-Bar features

- Designed and manufactured in Australia
- Comply with Australian Standards and Building Code requirements
- Manufactured under process-based quality control requirements
- Product certified by Unisearch Limited
- Fully machine welded
- 300 MPa grade steel
- All surfaces, including ends, fully hot-dip galvanised with 600 g/m² zinc coating
- R3 durability rating as standard finish

Control Joints

Where control joints are used as a required structural element, loading of the lintel should be reduced by one third.

Installation

Place Traditional T-Bar in position on brick piers, with minimum end bearing of 150mm.

Prop before bricklaying. Props must be no further than 1.2 metres apart and must remain in place until mortar has fully cured.

Apply mortar (minimum 1:4) to all brick faces in contact with the T-Bar.

The same number of courses must be laid internally and externally to prevent twisting of the T-Bar.

Notes on safe load tables for Traditional T-Bar

These load tables assume that:

- The web of the T-Bar is vertical
- The T-Bar is simply supported at both ends
- The T-Bar is loaded such that the load acts vertically and equally on both sides of the web
- The T-Bar can be considered to be fully supported laterally along its entire length
- UDL loads are constant along the length of the bar
- All loads, including the T-Bar and any brickwork, are considered
- Hot-dip galvanised to AS/ NZS4680:2006
- Loads in accordance with AS/ NZS1170.1:2002

If any of these conditions is not satisfied, the design should be referred to a qualified structural engineer.

Galintel® Traditional T-Bars – safe load tables

Note a minimum of three courses of bricks must be laid above the lintel.

Web = Vertical

Flange = Base or horizontal

■ Loads limited by deflection of 1/500 span

TRADITIONAL T-BAR 200 x 10 web 200 x 10 flange 33 kg/m	Span (mm)	2400	2700	3000	4900	5100	5700	6000
	Bar Length (mm)	2700	3000	3300	5200	5400	6000	6300
UDL (kg/m)		2806	2227	1750	409	363	261	224
Point Load (kg)		3435	3060	2760	1265	1170	935	845

TRADITIONAL T-BAR 250 x 10 web 200 x 10 flange 37 kg/m	Span (mm)	2400	4900	5100	5300	5700	6000
	Bar Length (mm)	2800	5200	5400	5600	6000	6300
UDL (kg/m)		2806	687	635	588	509	450
Point Load (kg)		3435	1700	1635	1570	1465	1390

TRADITIONAL T-BAR 250 x 12 web 200 x 10 flange 41 kg/m	Span (mm)	4900	5100	5700
	Bar Length (mm)	5200	5400	6000
UDL (kg/m)		812	721	518
Point Load (kg)		2510	2320	1860

GALINTEL® CAVI-T-BAR

SAFE LOAD TABLES



Galintel Cavi-T-Bar™
Australian Registered Design No 306215

Galintel Cavi-T-Bar™ Lintel

The Galintel Cavi-T-Bar™ lintel is the ideal solution for cavity walls, either double brick, or brick veneer with timber trusses.

The Cavi-T-Bar™ was developed in response to demand from builders for an economical substitute for built-up steel sections such as parallel flange channel and plate.

Similar to a T-Bar but with a special top flange incorporated into the upright section, the Galintel Cavi-T-Bar™ provides an off-the-shelf solution for cavity walls, hot-dip galvanised, fully engineered and university tested

Control Joints

Where control joints are used as a required structural element, loading of the lintel should be reduced by one third.

Cavi-T-Bar™ features

- New versatile lintel beam
- Convenient, economical substitute for built-up steel sections such as parallel flange channel and plate
- Up to 20% lighter than built-up steel sections of equivalent load capacity
- Fully hot-dip galvanised (600 g/m²)
- Available ex-stock from accredited Galintel® distributors
- Available in standard lengths
- Fully engineered and university tested
- Full product warranty

Galintel Cavi-T-Bar™ Safe Load Tables

Vertical Leg 180 x 8 Platform Leg 250 x 8 Mass 31 kg/m

Span (mm)	2400	2700	3000	3300	3600	4900	5100	5700	6000
Bar Length (mm)	2700	3000	3300	3600	3900	5200	5400	6000	6300
UDL (kg/m)	2800	2200	1760	1385	1080	440	390	285	245
Point Load (kg)	3570	3130	2770	2480	2230	1395	1290	1040	940

Vertical Leg 240 x 9.5 Platform Leg 250 x 8 Mass 41 kg/m

Span (mm)	2400	3000	3300	3600	4900	5100	5300	5700	6000
Bar Length (mm)	2700	3300	3600	3900	5200	5400	5600	6000	6300
UDL (kg/m)	5680	3520	2850	2340	1110	990	885	715	615
Point Load (kg)	7250	5550	4920	4400	2880	2720	2570	2300	2130

■ Loads limited by deflection of 1/500 span

Notes on Safe Load Tables for Cavi-T-Bar™

These load tables assume:

- The web of the Cavi-T-Bar™ is vertical.
- The Cavi-T-Bar™ is simply supported at both ends.
- The Cavi-T-Bar™ is loaded such that the load acts vertically and equally on both sides of the web.
- The Cavi-T-Bar™ is considered as being laterally unrestrained for the full span length.
- UDL loads are constant along the length of the bar.
- Point loads act at mid-span.
- 150mm minimum bearing support on to brickwork.
- Hot-dip galvanising to AS/NZS4680:2006.
- Loads are in accordance with AS/NZS1170.1:2002.

GALINTEL® CAVI-T-BAR

APPLICATIONS



Cavity Brick Applications

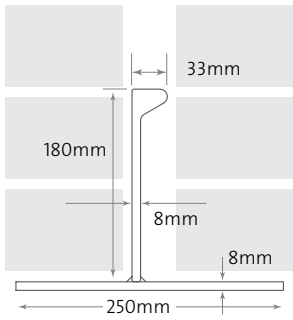
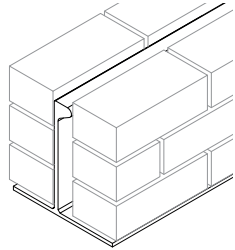
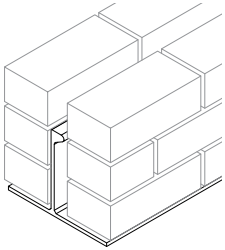

180mm Cavi-T-Bar™

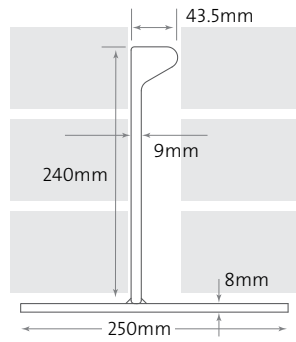

240mm Cavi-T-Bar™

Brick Veneer Applications

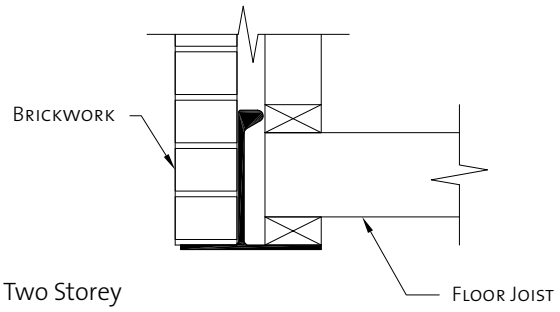

Two Storey

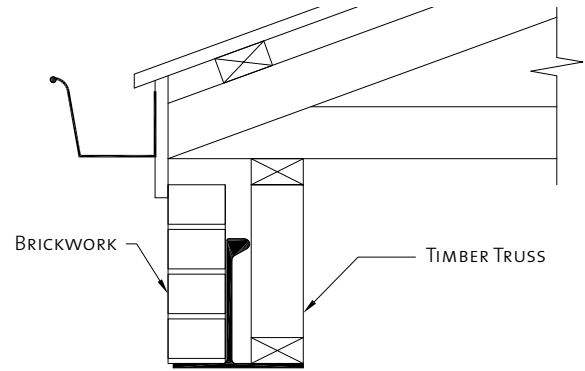

Single Storey

Standard Bolt Hole Details

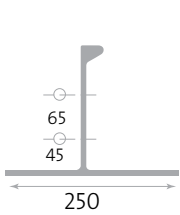

180mm Cavi-T-Bar™

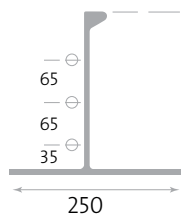

240mm Cavi-T-Bar™

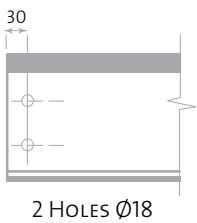

2 HOLES Ø18

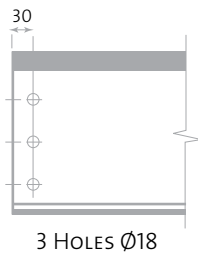

3 HOLES Ø18

Typical Built-up Steel Sections Replaced by Cavi-T-Bar™

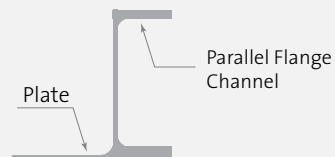
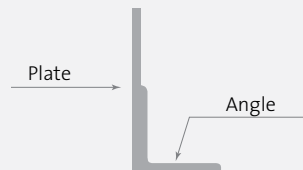
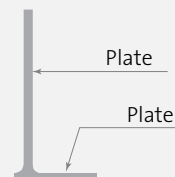

GALINTEL® T-BARS

SECTION PROPERTIES

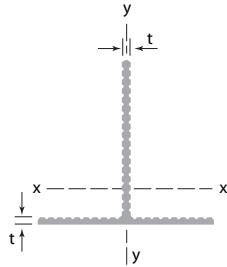

MULTI-RIB T-BAR	DIMENSIONS		SECTION PROPERTIES				
	Designation V= Vertical Leg B= Base mm x mm	Mass per metre	Gross Section Area	About x-axis		About y axis	
		kg/m	A	I_x	Z_x	I_y	$Z_{yt,b}$
	200x7(V) 200x7(B)	16.2	2060	$7.77 \times 10^6 \text{mm}^4$	$52.42 \times 10^3 \text{mm}^3$	$3.45 \times 10^6 \text{mm}^4$	$36.34 \times 10^3 \text{mm}^3$
200x9(V) 200x9(B)	22.1	2820	$11.1 \times 10^6 \text{mm}^4$	$74.67 \times 10^3 \text{mm}^3$	$4.6 \times 10^6 \text{mm}^4$	$45.41 \times 10^3 \text{mm}^3$	

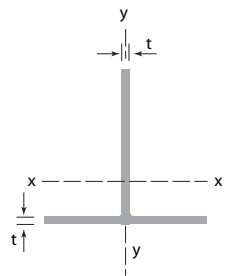

TRADITIONAL T-BAR	DIMENSIONS		SECTION PROPERTIES				
	Designation V= Vertical Leg B= Base mm x mm	Mass per metre	Gross Section Area	About x-axis		About y axis	
		kg/m	A	I_x	Z_x	I_y	Z_y
	200x10(V) 200x10(B)	31.6	4025	$17.76 \times 10^6 \text{mm}^4$	$116.2 \times 10^3 \text{mm}^3$	$6.68 \times 10^6 \text{mm}^4$	$66.8 \times 10^3 \text{mm}^3$
250x10(V) 200x10(B)	35.5	4525	$31.92 \times 10^6 \text{mm}^4$	$174.3 \times 10^3 \text{mm}^3$	$6.69 \times 10^6 \text{mm}^4$	$66.9 \times 10^3 \text{mm}^3$	
250x12(V) 200x10(B)	39.4	5025	$36.05 \times 10^6 \text{mm}^4$	$203.3 \times 10^3 \text{mm}^3$	$6.70 \times 10^6 \text{mm}^4$	$67.0 \times 10^3 \text{mm}^3$	

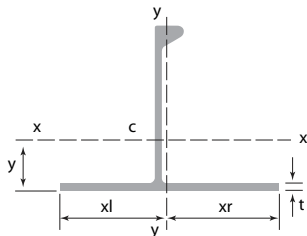

CAVI-T-BAR	DIMENSIONS		SECTION PROPERTIES					
	Designation V= Vertical Leg B= Base mm x mm	Mass per metre	Gross Section Area	About x-axis		About y axis		
		kg/m	A	I_x	Z_x	I_y	Z_{xl}	Z_{xr}
	180x8(V) 250x8(B)	30.7	3910	$18.53 \times 10^6 \text{mm}^4$	$316.88 \times 10^3 \text{mm}^3$	$10.60 \times 10^6 \text{mm}^4$	$87.92 \times 10^3 \text{mm}^3$	$81.9 \times 10^3 \text{mm}^3$
240x9(V) 250x8(B)	40.4	5152	$46.61 \times 10^6 \text{mm}^4$	$481.90 \times 10^3 \text{mm}^3$	$10.90 \times 10^6 \text{mm}^4$	$92.62 \times 10^3 \text{mm}^3$	$82.4 \times 10^3 \text{mm}^3$	

Designation: Vertical Leg (V) = Height x Thickness (t)
Base (B) = Width x Thickness (t)

FREQUENTLY ASKED QUESTIONS

EVERYTHING YOU NEED TO KNOW ABOUT GALINTELS®

How do I decide which Galintel® is best for my project?

Your design engineer should determine the type, size and length of Galintel® for the brickwork openings by consulting the relevant technical data and safe load tables.

Why are Galintel® products hot-dip galvanised?

Hot-dip galvanising (HDG) is the most economical form of providing corrosion protection for steel, to prevent rust. Brickwork cracking caused by rust displacement is virtually eliminated by the corrosion protection of HDG. HDG also offers excellent impact and scratch resistance to cope with the rigours of transport and handling on a building site.

What if I require a non-standard length Galintel®?

You may use a longer length of Galintel®, which will result in a longer end-bearing length. Where the end-bearing length is restricted, you can cut the Galintel® to the required length. The cut end must be cleaned, primed and painted with a zinc-rich paint (minimum 95% zinc content). However, product warranty would not apply.

Do I need to prop Galintels®?

Yes. During installation, props must be positioned and not removed until the mortar is cured. This allows the composite beam to form correctly and ensures level alignment of the brickwork. Props should be no further apart than 1.2m.

How many courses of bricks

are needed above a steel lintel?

The Building Code of Australia requires that not less than three courses of bricks must be used above a steel lintel to form an arching effect.

Can I weld to a Galintel®?

We don't recommend that you perform welding on Galintel® products as welding destroys the protective zinc coating. If welding is required, consult your design engineer.

Which Galintel® product is best suited for a rendered finish application?

Galintel Rendabar® is ideal, because it is specifically designed and developed for rendered applications.

Is there a Galintel® available for fire-rated structures?

Yes. Galintel Rendabar® has a fire rating of up to two hours, depending on the application. To achieve the designed fire rating, the Galintel Rendabar® must be cement-rendered after installation. The rendering must also meet relevant building codes and standards. For design information, refer to the Rendabar® Fire Rated Safe Load Table.

Are Galintels® suitable for buildings near the coast or in severe environments?

Galintels® are suitable for use in these areas, but additional coatings may be required. AS2312 specifies the types of additional protective coating needed to maintain the required service life in highly corrosive environments.

What guarantees do Galintels® offer?

Galintel Pty Ltd guarantees that all Galintel® products are free from defects in material and workmanship.

Galintels® have been appraised by the CSIRO, they comply with the requirements of the BCA and are designed and tested to meet the relevant sections of AS3700:2001 – Masonry structures.

Galintels® meet the requirements of the R3 durability classification, as defined in AS/NZS2699.3:2002.

Galintel® products have been recognised by the Australian Design Council with an Australian Design Award.

How do I identify a genuine Galintel® product?

Galintels® can be identified by their ribbed profile. All products in the Galintel® range are also clearly labelled to show the name, size, length, unit weight, month/year of manufacture and durability classification.

How do I ensure full composite action is achieved?

By ensuring that mortar is present at all contact surfaces between bricks and lintel and that the lintel is correctly propped during installation.

© Galintel design registered. Galintel, Galintel Rendabar and Galintel T-Bar names and products are subject to patent, registered design and trademark applications. © Graham Group Pty Ltd. All rights reserved. No part of this publication may be reproduced, stored in a retrieval system, electronic system or by any other means without prior written permission from Galintel Pty Ltd.

GALINTEL® STOCK LENGTH GUIDE

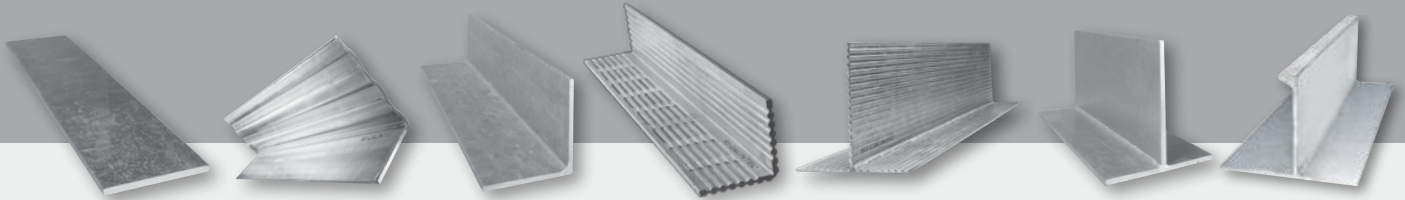

Traditional Flat

Solid Base Angle

Traditional Angle

Rendabar

Multi-Rib T-Bar

Traditional T-Bar

Cavi-T-Bar™

Always refer to engineer's specification for correct lintel section, size & installation.

Check availability of stock lengths before ordering

Maximum Clear Opening (mm)	Flat				Angle		
	85x7 Traditional	75x10 Traditional	100x100x6 Solid Base	150x100x6 Solid Base	100x75x10 Traditional	150x90x10 Traditional	150x100x10 Traditional
up to 600mm	800	800					
600 – 700	900	900	900		900		
700 – 800	1000	1000	1200				
800 – 900	1100	1100	1200		1200		
900 – 1000	1200	1200	1200		1200		
1000 – 1100		1500	1500		1500		
1100 – 1200		1500	1500		1500		
1200 – 1500		1800	1800	1800	1800	1800	
1500 – 1800			2100	2100	2100	2100	2100
1800 – 2100			2400	2400	2400	2400	2400
2100 – 2400			2700	2700	2700	2700	2700
2400 – 2700				3000	3000	3000	3000
2700 – 3000				3300		3300	3300
3000 – 3300				3600		3600	3600
3300 – 3600				4000		4000	4000
3600 – 4000							
4000 – 4200						4500	4500
4200 – 4500						5000	5000
4500 – 4800							
4800 – 5100						5500	5500
5100 – 5400							
5400 – 5700						6000	6000

Maximum Clear Opening (mm)	Rendabar®			T-Bar			Cavi-T-Bar™		
	100x100x8 Rendabar	150x100x8 Rendabar	200x200x7 Multi Rib	200x200x9 Multi Rib	200x200x10 Traditional	250/10x200/10 Traditional	250/12x200/10 Traditional	180/8x=250/8 Cavi-T-Bar™	240/9x=250/8 Cavi-T-Bar™
up to 600mm	900								
600 – 700	900		900						
700 – 800	1200		1200						
800 – 900	1200		1200						
900 – 1000	1200		1200						
1000 – 1100	1500		1500						
1100 – 1200	1500		1500						
1200 – 1500	1800	1800	1800						
1500 – 1800	2100	2100	2100						
1800 – 2100	2400	2400	2400						
2100 – 2400		2700	2700		2700	2800		2700	
2400 – 2700		3000	3000		3000			3000	
2700 – 3000		3300	3300		3300			3300	
3000 – 3300		3600	3600	3600				3600	3600
3300 – 3600		4000	3900	3900					3900
3600 – 4000				4200					4200
4000 – 4200				4500					4500
4200 – 4500				4800					4800
4500 – 4800				5100	5200	5200	5200		5200
4800 – 5100				5400	5400	5400	5400		5400
5100 – 5400				5700		5600			5700
5400 – 5700				6000	6000	6000	6000		6000
5700 – 6000				6300	6300	6300			



Galintel Pty Ltd

A division of the Graham Group

NEW SOUTH WALES

Available From:



26 Atkinson Road,
Taren Point, NSW 2229
Phone: 02 8543 3400
Fax: 02 8543 3460

